

## Snake Paver

### TECHNOLOGY



#### Flow Sense

A built-in protector against power-related issues, ensuring lasting performance and safety.



#### Split & Seal

Uses protective polymers to shield Filix products from water and moisture, boosting durability and resilience.



#### Heat Sense

Automatically reduces LED power at high temperatures, ensuring longevity and safety in Filix products.





## Snake Paver

Specification Sheet



UL STD 1598  
IP67

### LUMINAIRE FEATURES

#### Design and Application

- Architectural and landscape lighting
- Recessed floor installation
- Gravel, soil or concrete
- UL STD 1598, IP67, Wet location, drive over rated 1500 kg (3300lb)

#### Mechanical details

- IK10, laminated & tempered glass, 10mm (0.39") thick
- Continuous run
- Radius, min R 314mm (12.4")
- Stainless steel type 304 construction
- Direct concrete pour ABS installation housing
- Snap in installation with no exposed hardware
- Galvanic current protection (installation housing)

#### Electrical details

- LED Lifetime TM-21 @85C L90(9K)=60500h
- Supplied with oil and water resistant 0.18m (7") feed cable as standard
- CRI: > 85
- 3 Step MacAdam
- Remote power supply
- Low voltage operation

#### Sustainability

- Recyclable materials

#### Controls

- DMX, with compatible LED power supply
- DALI, with compatible LED power supply
- 0-10V, with compatible LED power supply
- Mains, with compatible LED power supply

#### Integrated systems

- Split & Seal
- Flow Sense
- Heat Sense

#### Links & Downloads

- [List of available drivers](#)
- [Voltage drop calculator](#)
- [Fixture installation manual](#)
- [Housing installation manual](#)
- [CAD files](#)
- [IES-LTD data](#)



# Snake Paver

## ORDERING INFORMATION

<b>MODEL</b>	
<b>SN</b>	
<b>LENGTH</b>	
<b>100</b>	• 121mm (4,8")
<b>POWER</b>	
<b>H</b>	• H - 2.3W, 2700K - 3000K, 80lm
<b>COLOR TEMP.</b>	
<b>27</b>	• 27 - 2700K
<b>30</b>	• 30 - 3000K
<b>RGBW</b>	• RGBW (W - 3000K)
<b>OPTICS</b>	
<b>LL</b>	• LL = 120° even illumination
<b>VOLTAGE</b>	
<b>24</b>	• 24 - 24VDC fixture voltage

\*Min order quantity 9pcs

\*Max run from single feed 7m (23')



## Snake Paver

### MANDATORY ACCESSORIES

#### Housing

HOUSING  
SN335

- SN335 - ABS Installation housing

#### End caps

END CAPS  
104891

- 104891 - End cap

#### Feed cable

FEED CABLE  
104921

- 104921 - Feed cable 1 m (3ft)

#### Power supplies

DRIVERS  
[LINK](#)

- [List of available drivers](#)



# Snake Paver

## INSTALLATION DETAILS

### Fixture

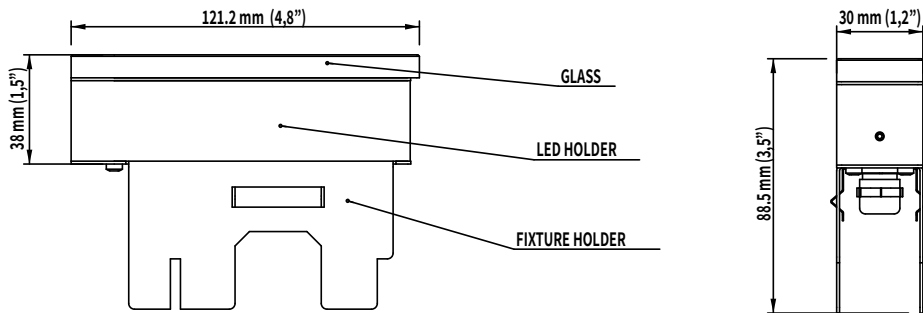

### Installation housing - SN335

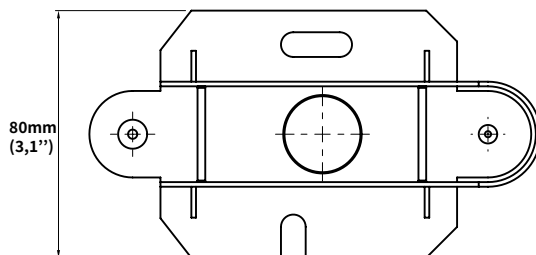
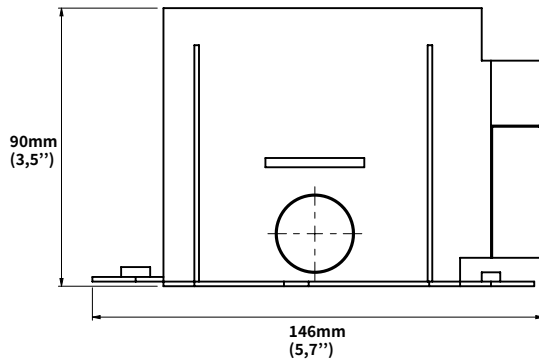

Note:  
For details on specific depths, tiling thickness and other please refer to both Installation instructions for fixture and housing.



## Snake Paver

### MANDATORY ACCESSORIES

#### Snap fit housing

Achieves seamless luminaire integration through precision press-fit design with no visible hardware. The recessed installation ensures strong retention against the mounting surface, while the push-in mechanism allows quick and effortless fixture placement into the housing.

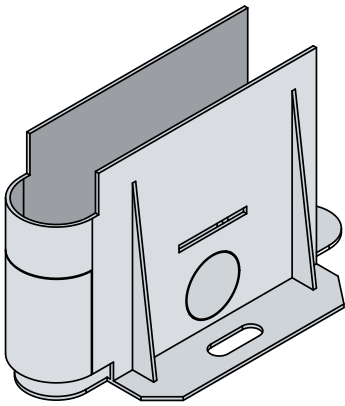

#### End cap

Endcap for receptacle, providing IP67 protection when securely locked. Required for all runs' terminations.

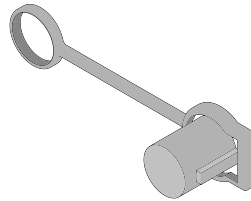

#### Power supply

A LED power supply, is an electrical device designed to control the power supplied to an LED or an array of LEDs. It plays a critical role in LED lighting systems as LEDs demand a specific type and level of electrical current or voltage for optimal operation. It's important to note whether a constant current or constant voltage LED power supply is required. The power supply should be installed in a dry and easily accessible area.

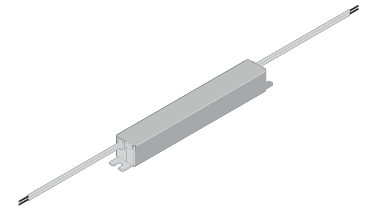

#### Feed cable

Standard length 1m (3ft). The rugged rubber cables are versatile, with open wires for mains connection and a snap-in connector for fixture connection. They're rated IP68/IP69K and resistant to UV exposure, ideal for marine use. Note that feed cables are mandatory to order

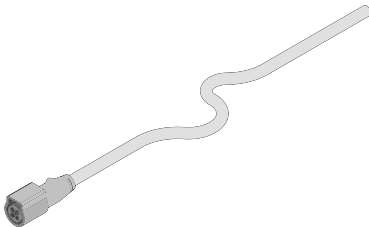



# Snake Paver

## OPTICS

LL

Angle: 120°

Delivered lumen: 80lm

Ceiling

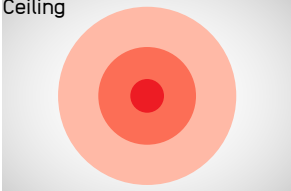

Wall

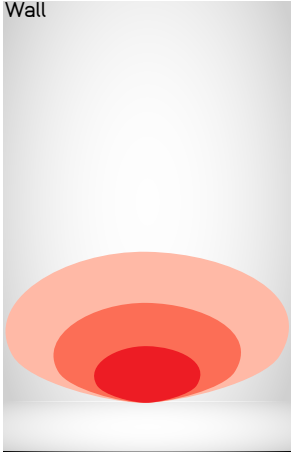

### Notes

- Light output values based on 2.3W and 3000K product



## Control

### ON/OFF SYSTEM TOPOLOGY

#### Integrated systems:

- Flow Sense
- Heat Sense
- Split & Seal

#### System components

- Wiring, protective devices and junction boxes leading up to feed cable at the start of the line are the responsibility of others
- Advised protective components:
  - Surge protector device
  - Inrush current limiter

#### System topology

- In the system design, any of the following system topologies can be utilized: line wiring, star wiring, or tree wiring.

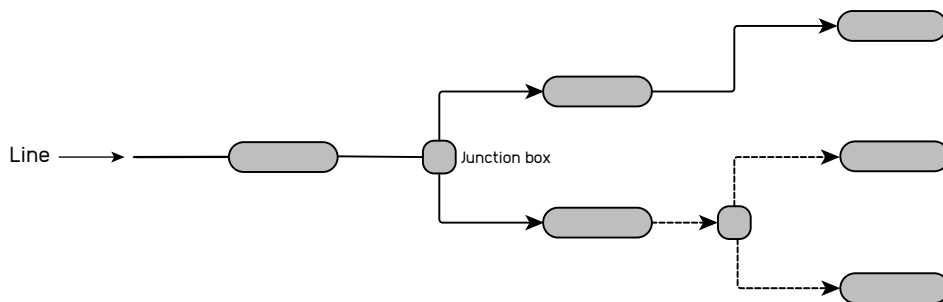

#### Addressing & dimming notes

- ON/OFF system does not allow device addressing
- Dimming of the product not available in this system

#### Segment length and limitations

- The maximum distance between the first and last fitting is limited to maximum voltage drop and fuse rating.
- Used only in single colour applications

#### Fault tolerance

- If one product fails the rest of the system continues to work
- Class III wiring implemented in the fixture and voltage fluctuation filter implemented



## Control

### 0-10V SYSTEM TOPOLOGY

#### Integrated systems:

- Flow Sense
- Heat Sense
- Split & Seal

#### System components

- The 0-10V system, wiring, protective devices and junction boxes leading up to feed cable at the start of the line are the responsibility of others
- Advised protective components:
  - Surge protector device
  - Inrush current limiter

#### System topology

- In the system design, any of the following system topologies can be utilized: line wiring, star wiring, or tree wiring.

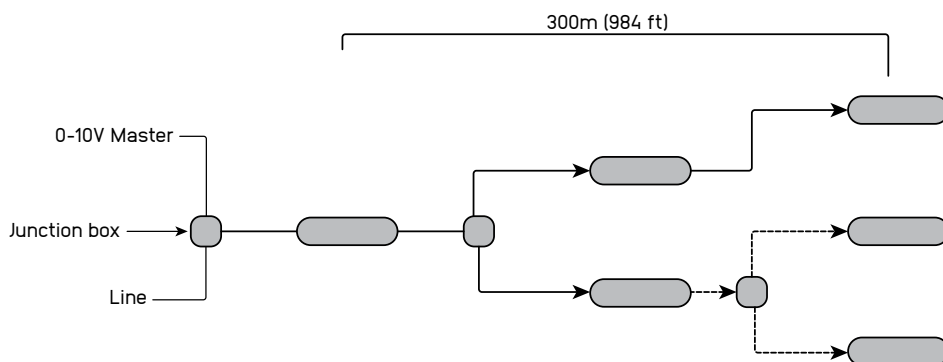

#### Addressing & dimming notes

- 0-10V protocol does not allow addressing devices individually
- Logarithmic and linear dimming options are available, depending on the power supply. The product itself is not equipped with a decoder. Power supplies can include logarithmic dimming settings, which are recommended in most cases, as this dimming curve is generally preferred due to the way it is perceived by the human eye.
- 0%-100% dimming range

#### Segment length and limitations

- The maximum distance between two fittings is 30 meters, and the maximum distance between the first and last fitting is 300 meters.
- Used in single colour applications

#### Fault tolerance

- If one product fails the rest of the system continues to work
- Class III wiring implemented in the fixture and voltage fluctuation filter implemented



## Control

### DALI SYSTEM TOPOLOGY

#### Integrated systems:

- Flow Sense
- Heat Sense
- Split & Seal

#### System components

- The DALI system, wiring, protective devices and junction boxes leading up to feed cable at the start of the line are the responsibility of others
- Advised protective components:
  - Surge protector device
  - Inrush current limiter

#### System topology

- In the system design, any of the following system topologies can be utilized: line wiring, star wiring, or tree wiring.

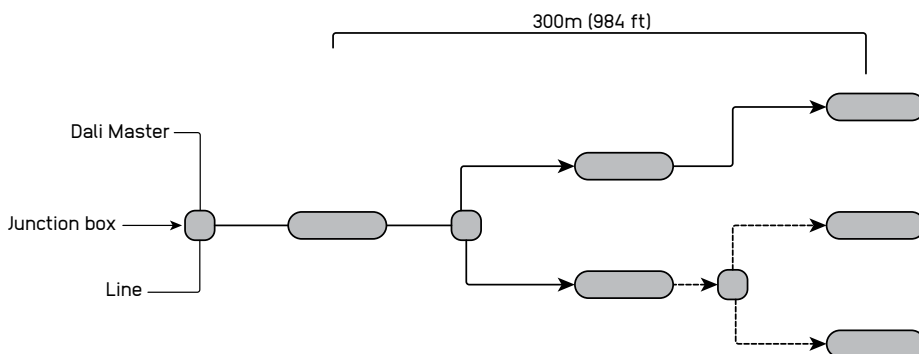

#### Addressing & dimming notes

- DALI protocol allows addressing devices individually
- Addressing methods include a short address for individual devices, group addresses for up to 16 groups, and a broadcast address that targets everything on the line.
- Logarithmic and linear dimming options are available, depending on the power supply. The product itself is not equipped with a decoder. Power supplies can include logarithmic dimming settings, which are recommended in most cases, as this dimming curve is generally preferred due to the way it is perceived by the human eye.
- 0%-100% dimming range

#### Segment length and limitations

- A DALI master has the capacity to manage a line containing a maximum of 64 devices.
- The maximum distance between two fittings is 30 meters [98ft], and the maximum distance between the first and last fitting is 300m [984ft].
- Used in single colour and tunable white applications

#### Fault tolerance

- Due to its relatively slow operating speed and high bus voltage, the DALI system exhibits significant reliability in the presence of electrical interference, making shielding unnecessary
- If one product fails the rest of the system continues to work



## Control

### DMX SYSTEM TOPOLOGY

#### Integrated systems:

- Flow Sense
- Heat Sense
- Split & Seal

#### System components

- The DMX system, wiring, protective devices and junction boxes of the line are the responsibility of others
- Advised protective components:
  - Surge protector device
  - Inrush current limiter

#### System topology

- In the system design, line wiring can only be used

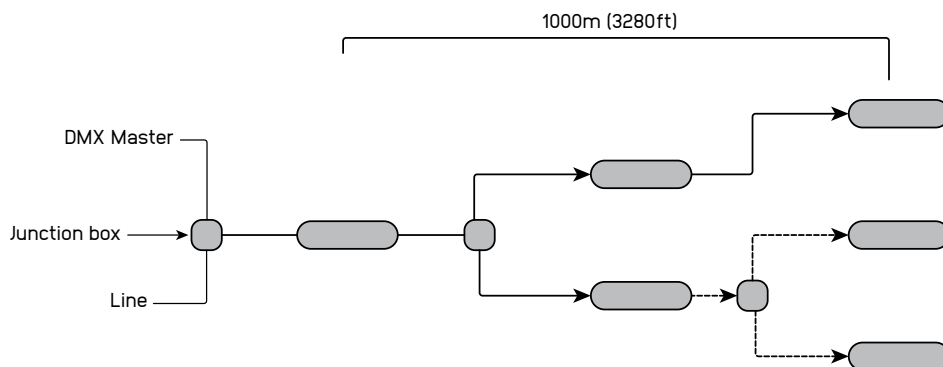

#### Addressing & dimming notes

- DMX protocol allows addressing devices individually
- Addressing methods allow short address for individual devices
- Logarithmic and linear dimming options are available, depending on the power supply. The product itself is not equipped with a decoder. Power supplies can include logarithmic dimming settings, which are recommended in most cases, as this dimming curve is generally preferred due to the way it is perceived by the human eye.
- 0%-100% dimming range

#### Segment length and limitations

- A DMX universe has the capacity to manage a line containing a maximum of 512 addresses.
- The maximum distance between two fittings is 30m (98ft), and the maximum distance between the first and last fitting is 1000 meters
- Used in single colour, tunable white, and RGBW applications

#### Fault tolerance

- If one product fails the rest of the system continues to work